

DIAMOND

Is a wafer type ball valve with flanged connections. DIAMOND ball valves in stainless steel, of solid and advanced design is backed by the twenty-year experience gained by ENOLGAS in production of ball valves.

In order to keep tolerances and material quality constant, investment casting of body and end adapter was preferred to forging, with careful subsequent toolings on CNC machines, which guarantee a high quality standard.

Leading design and accurate machining and finishing of the valves guarantee a perfect tightness and lifetime troubleless working operations.

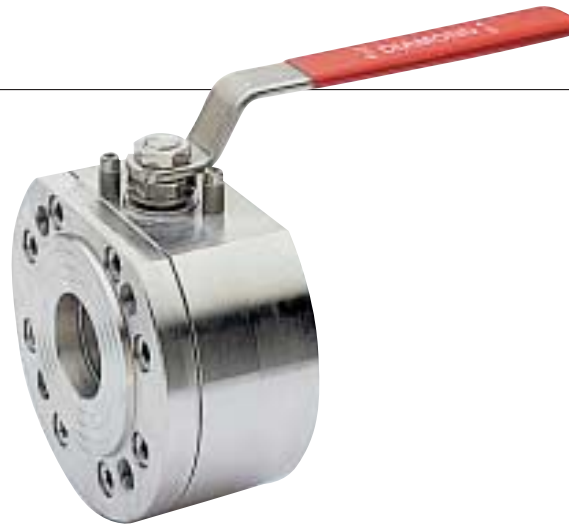

INDUSTRIAL VALVES

TECHNICAL FEATURES

- Full bore
- Blow-out proof stem
- Antistatic device
- Stem sealing o-ring
- Sealing packings interchangeable
- Blow-out proof stem with triple labyrinth sealing system adjustable by Belleville washers.
- Low pressure and vacuum stem sealing through Fluoroelastomer O-ring.
- The sealing between body and flange is obtained through a triple barrier: a first resilient seal in PTFE, a second metallic seal and a third seal in pure graphite.
- Self-adjusting stem sealing
- Equipped with wrapping seats ensuring long life cycles, with perfect air bubble-free sealing.
- Maintenance free.
- All valves are tested at 25 bar pressure, for a period exceeding 48 hours.
- Fire safe to BS 6755, API 6FA, API 607.
- Connection with actuators to ISO 5211.
- General prescriptions to BS 5351.

END CONNECTIONS

Flanges to UNI 2223-2229
DIN 2501 BL. 1
ANSI B16.5.

WORKING PRESSURE

Standard PN 16
On request PN 25/PN 40
and ANSI 150.

TEMPERATURE LIMITS

From -20°C to +180°C.

UTILISATION

DIAMOND is suitable for air, gas, water, oil and for industrial plants.
For special uses, see the table of chemical resistance.

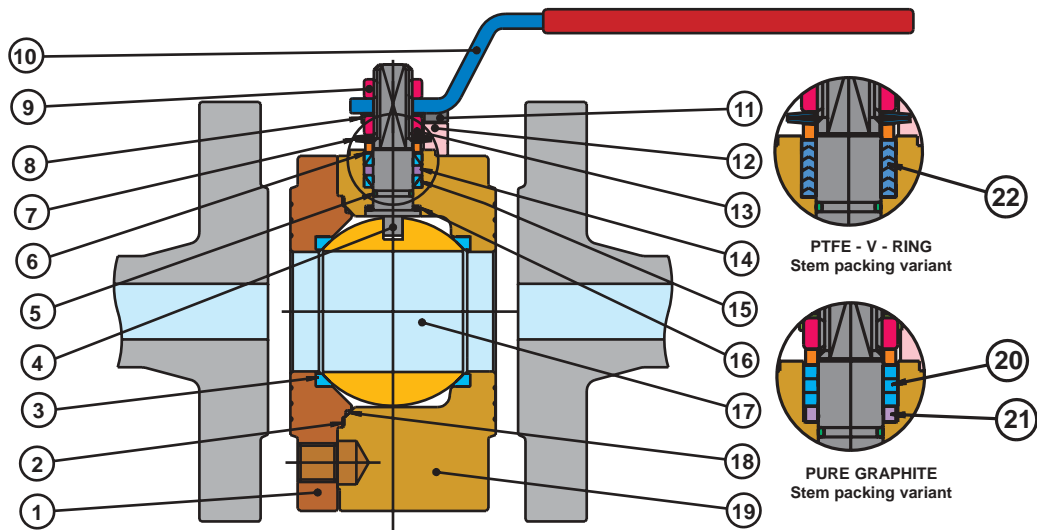

Item	Description	DIAMOND stainless steel		DIAMOND carbon steel	
1	Metal ring	From bar	AISI 316 D 1.4401	A 105	
2	Outside static ring	From bar	Pure graphite	Pure graphite	
3	Ball seats	From bar	Virgin P.T.F.E.	Virgin P.T.F.E.	
4	Stem	From bar	AISI 316 D 1.4401	AISI 304	D 1.4301
5	O-ring	Green or black	Fluoroelastomer	Fluoroelastomer	
6	Packing washer	From bar	AISI 304 D 1.4301	AISI 304	D 1.4301
7	Spring washers	Drawn	AISI 301 D 1.4310	50CrV4	
8	Fixing nut plat	Blanked	AISI 304 D 1.4301	AISI 304	D 1.4301
9	Locking nut	Forged	AISI 304 D 1.4301	A 105	
10	Lever handle	P.V.C. insulated red color	AISI 304 D 1.4301	A 105	
11	Screw for oper. stop	Forged	AISI 304 D 1.4301	A 105	
12	Operation stop	Blanked	AISI 304 D 1.4301	A 105	
13	Stem retaining nut	Forged	AISI 304 D 1.4301	A 105	
14	Upper ring	From bar	Virgin P.T.F.E.	Virgin P.T.F.E.	
15	Stem packing	From bar	Virgin P.T.F.E.	Virgin P.T.F.E.	
16	Thrust washer	From bar	Virgin P.T.F.E.	Virgin P.T.F.E.	
17	Ball	Forged	AISI 316 D 1.4401	AISI 304	D 1.4301
18	Static gasket	From bar	Virgin P.T.F.E.	Virgin P.T.F.E.	
19	Body	From bar	AISI 316 D 1.4401	A 105	
20	Upper stem packing	From band	Pure graphite	Pure graphite	
21	Packing gland	From bar	AISI 304 D 1.4301	AISI 304	D 1.4301
22	Chevron type seals	From bar	P.T.F.E.+graphite	P.T.F.E.+graphite	

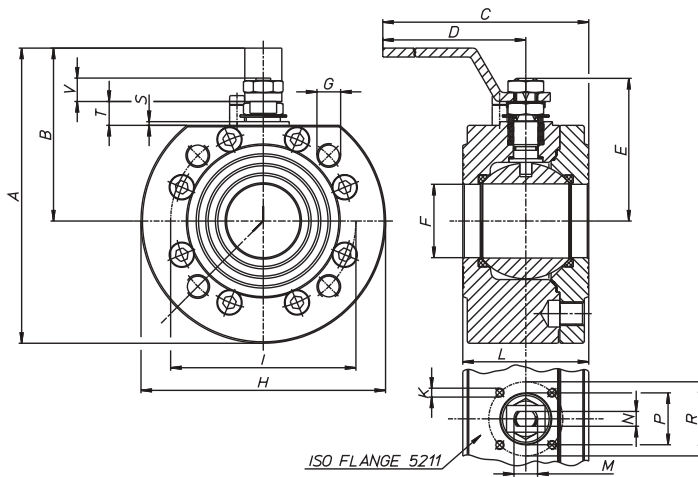

ISO FLANGE 5211

- 15% GLASS-FILLED PTFE with temperature limits -20°C + 195°C
- PTFE+CARBOGRAPHITE with temperature limits -20°C + 210°C
- Integral seats in PTFE up to DN 100
- DN 125 to DN 200 PN 25/40
- Reduction gear with manual operation
- Degreased version
- Body in LF2
- For further special requests please consult our technical/commercial service

AVAILABLE ACCESSORIES

Extended stem for insulated pipes.

Size	A mm	B mm	C mm	D mm	E mm	F mm	G mm	H mm	K mm	I mm	L mm	M mm	N mm	P mm	R mm	S mm	T mm	V mm	Z mm	N° holes	PN	ISO FLANGE	weight gr.
DN50	199	117	273	230	94,5	49,5	M16	165	M6	125	85	M16	10	35	50	2,5	16	14	-	4	40	F05	11000
DN65	232	239	372	320	119,5	65	M16	185	M8	145	103	M22	14	55	70	3	19	20,5	-	4	16	F07	17500
DN65	232	139	372	320	119,5	65	M16	185	M8	145	103	M22	14	55	70	3	19	20,5	-	8	40	F07	17300
DN80	249	149	381	320	129,5	78	M16	200	M8	160	122	M22	14	55	70	3	19	20,5	-	8	40	F07	22800
DN100	277	167	448	370	148,5	96	M16	220	M10	180	155	M27	16	70	102	3	22,2	25,3	-	8	16	F10	34500
DN100	284	167	448	370	148,5	96	M20	235	M10	190	155	M27	16	70	102	3	22,2	25,3	-	8	40	F10	39000
DN125	309	181	455	370	166,5	118	M16	255	M10	210	185	M27	16	70	102	3	22,2	25,3	-	8	16	F10	54200
DN125	316	181	455	370	166,5	118	M22	270	M10	220	185	M27	16	70	102	3	22,2	25,3	-	8	40	F10	61720
DN150	396	249	689	584	200	144	M20	295	M12	240	235	M42	26	-	125	-	4	31,5	650	8	16	F12	90570
DN150	396	249	702	584	200	144	M24	295	M12	250	235	M42	26	-	125	-	4	31,5	650	8	16	F12	91900
DN200	475	288	739	584	235	192	M20	365	M12	295	310	M42	26	-	125	-	4	27	650	12	16	F12	177060
DN200	475	288	739	584	235	192	M27	373	M12	320	310	M42	26	-	125	-	4	27	650	12	16	F12	183000

Breaking Torque in Nm

DN size	50	65	80	100	125	150	200		
PN - bar	0	35	55	75	150	240	310	600	
	16	39	59	84,5	168	300	400	800	
	25	41,5	62,5	92	180				
	40	44	67	99	195				
Nm									

Values in Nm can change depending on the material used for seats, on temperature and on the fluid used.
For a safe working of the various sorts of servocontrol, it is necessary to consider a

safety factor = 1,5 in each condition. While the valve is working, with frequent on/off cycles, the operating torque can become extremely low in comparison with the beginning one.

PRESSURE/TEMPERATURE DIAGRAM

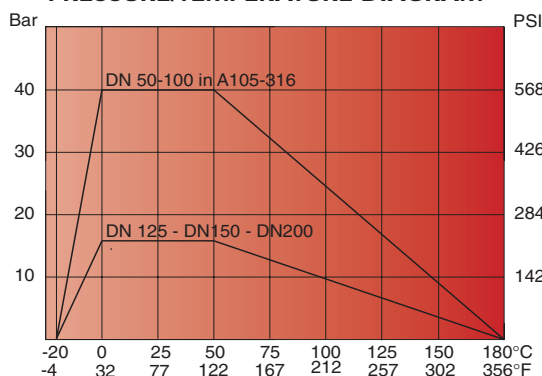

LOSS OF HEAD DIAGRAM

