

# CAST TOPAZ

Ball valve in stainless steel, of solid and advanced design is backed by the twenty-year experience gained by ENOLGAS in production of ball valves.

In order to keep tolerances and material quality constant, investment casting of body and end adapter was preferred to forging, with careful subsequent toolings on CNC machines, which guarantee a high quality standard.

Leading design and accurate machining and finishing of the valves guarantee a perfect tightness and lifetime troubleless working operations.



INDUSTRIAL VALVES

## TECHNICAL FEATURES

Full bore.

The machining of the body takes place on CNC high precision machines so as to guarantee the compliance with the design specifications.

Possibility of stops at 90° by operation without lever.

Blow-out proof stem with labyrinth sealing system adjustable by Belleville washers.

Equipped with wrapping seats ensuring long life cycles.

Perfect air bubble-free sealing.

Maintenance free.

All valves are tested at 25 bar pressure, for a period exceeding 48 hours.

Fire safe to BS 6755, API 6FA, API 607.

General prescriptions to BS 5351.

Connection with actuators to ISO 5211.

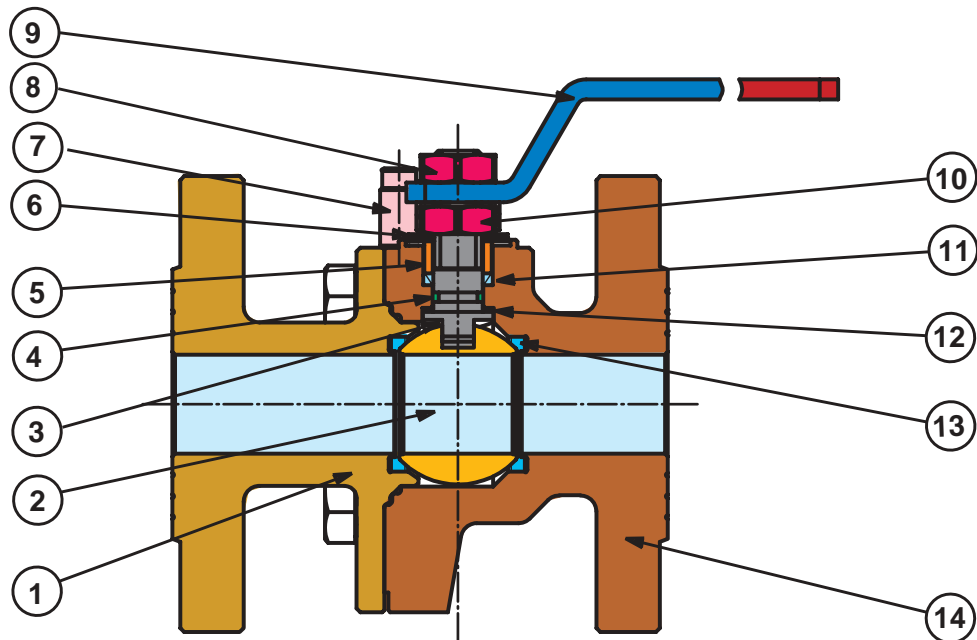

## END CONNECTIONS

Flanges to UNI 2223-2229  
DIN 2501 BL. 1  
DIN 3202  
ANSI B 16.5  
ANSI B 16. 10.

## WORKING PRESSURE

PN 16/40 and ANSI 150.

## TEMPERATURE LIMITS

From -20°C to +180°C.

## UTILISATION

TOPAZ is suitable for air, gas, water, oil and for industrial plants.

Item	Description	TOPAZ stainless steel		TOPAZ carbon steel	
1	Body	From bar	AISI 316 D 1.4401	A 105	
2	Ball	Forged	AISI 316 D 1.4401	AISI 304	D 1.4301
3	Stem	From bar	AISI 316 D 1.4401	AISI 304	D 1.4301
4	O-ring	Green or black	Fluoroelastomer	Fluoroelastomer	
5	Packing washer	From bar	AISI 316 D 1.4401	AISI 304	D 1.4301
6	Spring washers	Drawn	AISI 301 D 1.4310	50CrV4	
7	Operation stop pin	From bar	AISI 304 D 1.4301	Carbon steel 8.8	
8	Locking nut	Forged	AISI 304 D 1.4301	A 105 Nickel-plated	
9	Lever handle	P.V.C. insulated red color	A 105 Nickel-plated		A 105 Nickel-plated
10	Stem retaining nut	Forged	AISI 304 D 1.4301	A 105 Nickel-plated	
11	Upper stem packing	From bar	Virgin P.T.F.E.*	Virgin P.T.F.E.*	
12	Thrust washer	From bar	Virgin P.T.F.E.*	Virgin P.T.F.E.*	
13	Ball seats	From bar	Virgin P.T.F.E.	Virgin P.T.F.E.	
14	Body flange	From bar	AISI 316 D 1.4401	A 105	

\* Graphite, for fire safe.

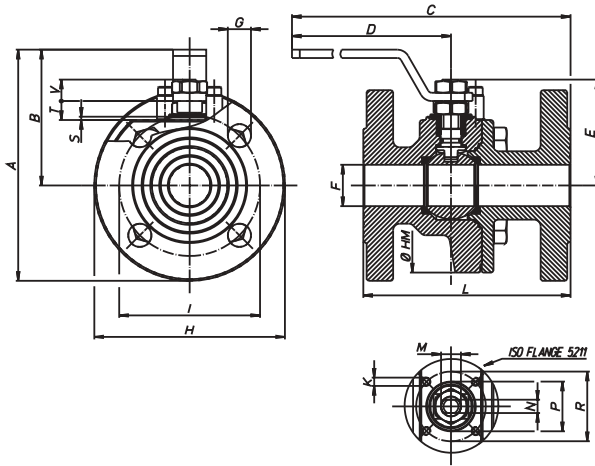

- 15% GLASS-FILLED PTFE with temperature limits -20°C + 195°C
- PTFE+CARBOGRAPHITE with temperature limits -20°C + 210°C
- Degreased version
- Antistatic device from DN15 to DN32
- On request the valve is available with ATEX certificate
- Body in LF2
- For further special requests please consult our technical/commercial service

### AVAILABLE ACCESSORIES

Extended stem for insulated pipes.

Size	A mm	B mm	C mm	D mm	E mm	F mm	G mm	H mm	K mm	I mm	L mm	M mm	N mm	P mm	R mm	S mm	T mm	V mm	HM mm	N° holes	PN	ISO FLANGE	weight gf.
DN15	113,5	66	207	140	48	15	14	95	M5	65	115	M10	6	-	36	-	5	9	-	4	40	F03	3600
DN20	121,5	69	210	140	51	20	14	105	M5	75	120	M10	6	25	36	2	8	9	-	4	40	F03	4635
DN25	139,5	82	252	180	62,3	25	14	115	M5	85	125	M12	8	30	42	2	11,5	11,5	105	4	40	F04	4930
DN32	157	87	257	180	67	32	18	140	M5	100	130	M12	8	30	42	2	10	11	-	4	40	F04	8320
DN40	183	108	312	230	87,3	40	18	150	M6	110	140	M16	10	35	50	2,5	14,5	15,5	140	4	40	F05	8700
DN50	197,5	115	317	230	94,5	49,5	18	165	M6	125	150	M16	10	35	50	2,5	14,5	15,5	155	4	40	F05	12930
DN65	231	139	418	320	119,5	65	18	185	M8	145	170	M22	14	55	70	3	18,7	20,8	183	4	16	F07	19204
DN80	250	150	425	320	130	78	18	200	M8	160	180	M22	14	55	70	3	18,7	20,8	198	8	40	F07	23520
DN100	273	163	484	370	148,5	96	18	220	M10	180	190	M27	16	-	102	-	1,5	26	218	8	16	F10	30230
DN125	306	181	603	370	166,5	118	18	250	M10	210	325	M27	16	70	102	3	22	26	246	8	16	F12	56100
DN150	392	249	771	584	200	144	22	285	M12	240	350	M42	26	-	125	-	4	31,5	287	8	16	F12	85200
DN200	460	288	784	584	235	192	22	343	M12	295	400	M42	26	-	125	-	4	27	377	12	16	F12	150200

### Breaking Torque in Nm

DN size	15	20	25	32	40	50	65	80	100	
PN - bar	0	4	7	10	16	25	35	55	75	150
	16	4,8	8,5	11,3	19	28	39	59	84,5	168
	25	5,2	9,1	12	20,5	29,5	41,5	62,5	92	180
	40	6	10,5	13	22,5	31,5	44	67	99	195

**Nm**

Values in Nm can change depending on the material used for seats, on temperature and on the fluid used.  
For a safe working of the various sorts of servocontrol, it is necessary to consider a

safety factor = 1,5 in each condition. While the valve is working, with frequent on/off cycles, the operating torque can become extremely low in comparison with the beginning one.

