

CILINDRI A PROFILO TONDO CP95 INOX Ø32-63

STAINLESS STEEL CP95 ROUND PROFILE CYLINDERS Ø32-63



TESTATE COVERS	ACCIAIO INOX AISI 304 AISI 304 STAINLESS STEEL
TUBO TUBE	ACCIAIO INOX AISI 304 AISI 304 STAINLESS STEEL
PISTONE PISTON	ALLUMINIO ALUMINIUM
GUARNIZIONI SEALS	POLIURETANO POLYURETHANE
BRONZINA BUSH	BRONZO SINTERIZZATO SINTERED BRONZE
ASTA PISTON ROD	ACCIAIO INOX AISI 316 AISI 316 STAINLESS STEEL

PRESSIONE DI FUNZIONAMENTO
WORKING PRESSURE

MAX 10 BAR

TEMPERATURA DI IMPIEGO
TEMPERATURE

-35°C +80°C CON ARIA SECCA
-35°C +80°C WITH DRY AIR

FLUIDO
WORKING FLUID

ARIA COMPRESSA FILTRATA E LUBRIFICATA E NON
FILTERED AND LUBRICATED OR NOT COMPRESSED AIR

VERSIONI DISPONIBILI AVAILABLE VERSIONS

CDEI_ - CDEMI_ - CDEPI_ - CDEMPI_

CORSE STANDARD STANDARD STROKES

Ø mm	10	25	40	50	80	100	125	160	200	250	300
32	☒	☒	☒	☒	☒	☒	☒	☒	☒	☒	☒
40	☒	☒	☒	☒	☒	☒	☒	☒	☒	☒	☒
50	☒	☒	☒	☒	☒	☒	☒	☒	☒	☒	☒
63	☒	☒	☒	☒	☒	☒	☒	☒	☒	☒	☒

DOPPIO EFFETTO
DOUBLE ACTING

DOPPIO EFFETTO

DOUBLE ACTING

CDEIØ/...

CDEMIØ/...

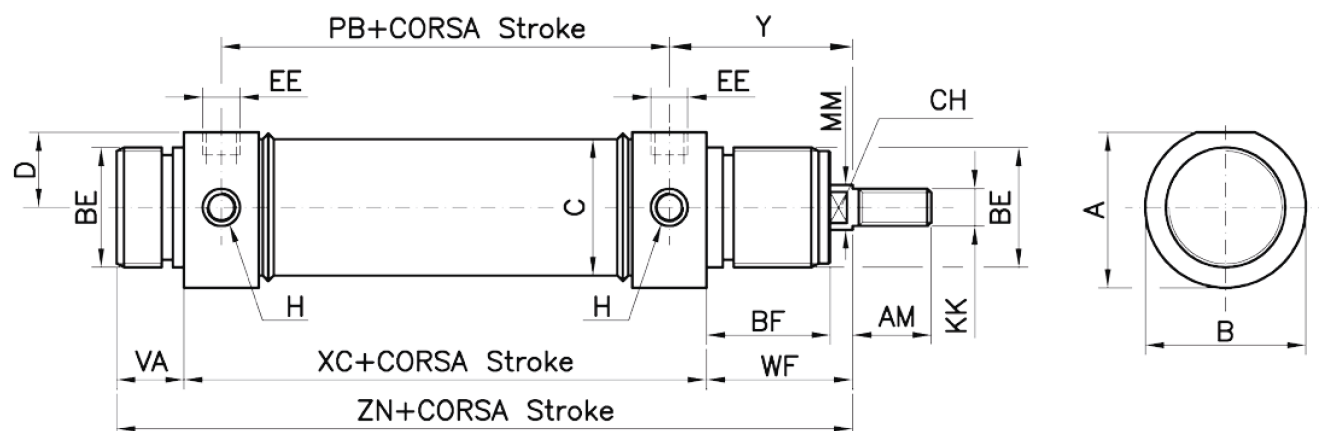

DIMENSIONI

DIMENSIONS

Ø mm	A	B	AM	BE	BF	EE	KK	H	MM	PB	VA	WF	Y	ZN	C	D	CH	XC
32	36.5	38	20	M30x1.5	30	1/8"G	M10x1.5	M8x1	12	78	14	38	47	148	33.6	17.5	10	96
40	44	46	24	M38x1.5	35	1/4"G	M12x1.75	M10x1	16	89	16	45	57	174	41.6	21	13	113
50	55	57	32	M45x1.5	38	1/4"G	M16x2	M12x1.5	20	96	18	50	62	188	52.4	26.5	17	120
63	67.5	70	32	M45x1.5	38	3/8"G	M16x2	M14x1.5	20	98	18	50	63	192	65.4	32.5	17	124

FORZE DI TRAZIONE E SPINTA (6 BAR)

TRACTION AND THRUST FORCES (6 BAR)

Ø mm	FORZA DI SPINTA (N) THRUST FORCE (N)	FORZA DI TRAZIONE (N) TRACTION FORCE (N)
32	458	394
40	716	601
50	1180	939
63	1775	1600

DOPPIO EFFETTO STELO PASSANTE

DOUBLE ACTING THROUGH PISTON ROD

CDEPIØ/...

CDEMPIØ/...

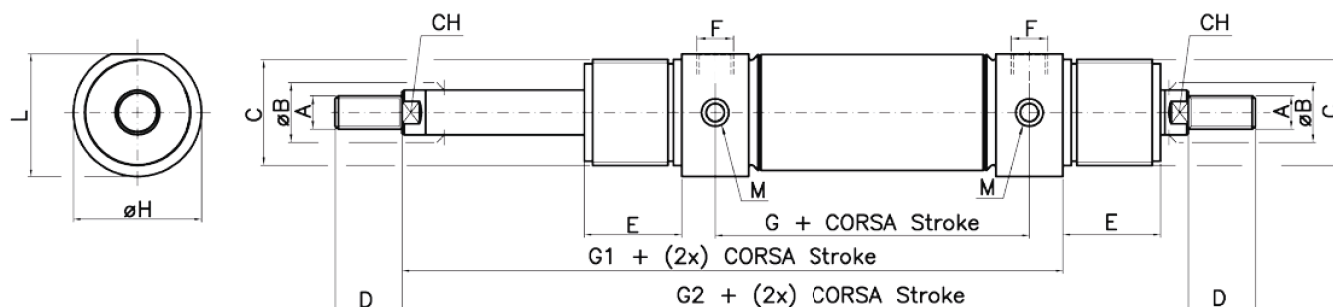

DIMENSIONI DIMENSIONS

Ø mm	A	ØB	C	D	E	F	G	G1	G2	ØH	L	M	CH
32	M10x1.5	12	M30x1.5	20	30	1/8"G	78	134	172	38	36.5	M8x1	10
40	M12x1.75	16	M38x1.5	24	35	1/4"G	89	158	203	46	44	M10x1	13
50	M16x2	20	M45x1.5	32	38	1/4"G	96	170	220	57	55	M12x1.5	17
63	M16x2	20	M45x1.5	32	38	3/8"G	98	174	224	70	67.5	M14x1.5	17

FORZE DI TRAZIONE E SPINTA (6 BAR) TRACTION AND THRUST FORCES (6 BAR)

Ø mm	FORZA DI SPINTA (N) THRUST FORCE (N)	FORZA DI TRAZIONE (N) TRACTION FORCE (N)
32	394	394
40	601	601
50	939	939
63	1600	1600

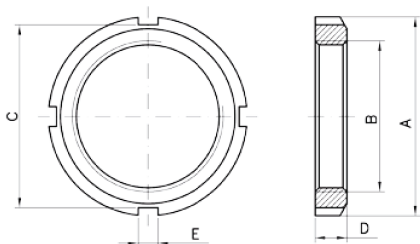

GHIERA / SLOTTED NUT

Ø mm	A	B	C	D	E	CODICE/CODE
32	45	M30x1.5	40	7	5	AN32I
40	50	M38x1.5	46	8	5	AN40I
50-63	58	M45x1.5	52	9	6	AN50/63I

MATERIALI: ACCIAIO AISI 304
MATERIALS: AISI 304 STEEL

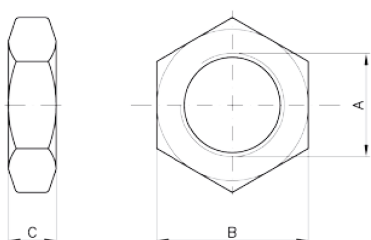

DADO PER ASTE / NUT FOR PISTON ROD

Ø mm	A	B	C	CODICE/CODE
32	M10x1.5	17	6	ANA32I
40	M12x1.75	19	7	ANA40I
50-63	M16x2	24	8	ANA50/63I

MATERIALI: ACCIAIO AISI 304
MATERIALS: AISI 304 STEEL

MATERIALI:
PERNI E CORPO IN ACCIAIO AISI304
BUSSOLE IN DELRIN
MATERIALS:
AISI304 STEEL BODY AND PIVOTS
DELRIN BUSHES

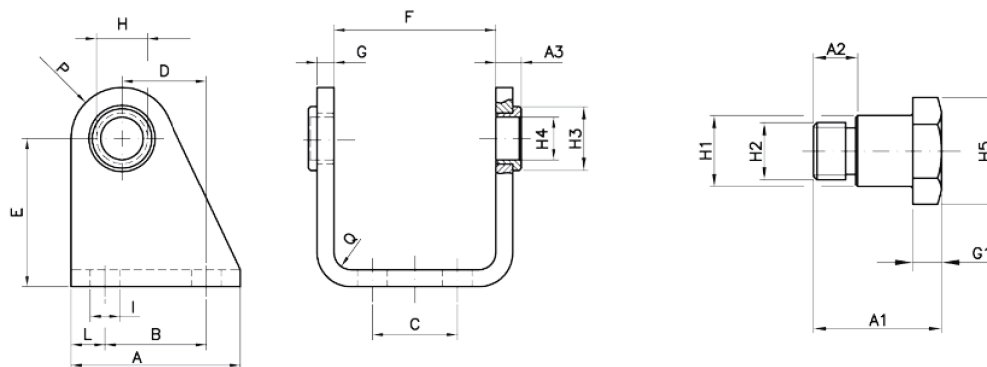

CERNIERA / HINGE

Ø mm	A	A1	A2	A3	B	C	D	E	F	G	G1	H	H1	H2	H3	H4	H5	I	L	P	Q	CODICE/CODE
32	40	18	6	6	24	20	20	35	38.1	4	4	12	10	M8x1	15	10	13	7	8	12	4	ACB32I
40	50	21.6	7	7	30	28	27	40	46.1	5	5	15	12	M10x1	20	12	17	9	10	13	5	ACB40I
50	54	26.4	9	8.5	34	36	30	45	57.1	6	6	18	14	M12x1.5	23	14	19	9	10	14	6	ACB50I
63	65	31.5	13	8.5	35	42	34	50	70.1	6	6	20	16	M14x1.5	23	16	19	9	15	16	6	ACB63I

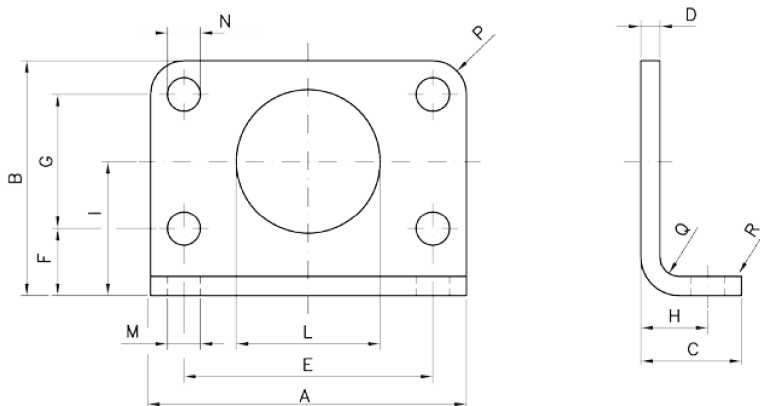

MATERIALI: ACCIAIO AISI304
MATERIALS: AISI304 STEEL

PIEDINO FLANGIA / FOOT FLANGE

Ø mm	A	B	C	D	E	F	G	H	I	L	M	N	P	Q	R	CODICE/CODE
32	66	49	21	4	52	14	28	14	28	30	7	7	7	4	2	AF32I
40	80	58	30	5	60	18	30	20	33	38	9	9	10	5	2	AF40I
50	90	70	30	6	70	20	40	20	40	45	9	9	10	6	2	AF50I
63	96	80	30	6	76	20	50	20	45	45	9	9	10	6	2	AF63I

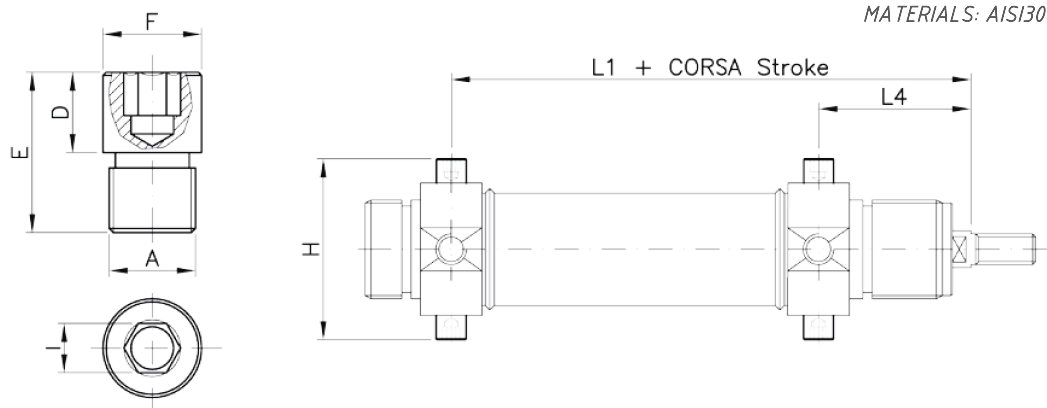

MATERIALI: ACCIAIO AISI304
MATERIALS: AISI304 STEEL

PERNO SINGOLO (PER) - COPPIA DI PERNI (AP) / SINGLE PIVOT (PER) - PAIR PIVOTS (AP)

Ø mm	A	D	E	F	I	H	L1	L4	CODICE/CODE	CODICE/CODE
32	M8x1	8	14	10	5	51	125	47	PER32I	AP32I
40	M10x1	9.5	16.5	12	6	61	146	57	PER40I	AP40I
50	M12x1.5	11	20	14	6	75	158	62	PER50I	AP50I
63	M14x1.5	13	28	16	8	92	161	63	PER63I	AP63I

MATERIALI: ACCIAIO AISI304
 MATERIALS: AISI304 STEEL

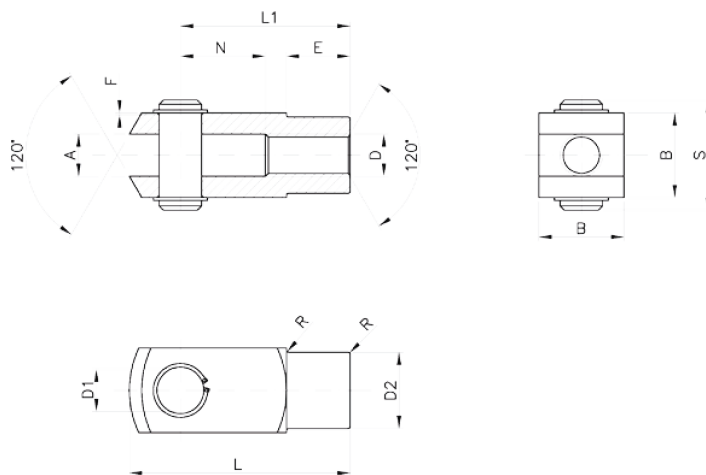

FORCELLA COMPLETA DI CLIP/CLEVIS WITH LOCKABLE PIN

D	A	F	L1	N	E	B	D1	R	D2	L	S	CODICE/CODE
M10x1.5	10	0.5	40	20	15	20	10	0.5	18	52	25	FORM10DINI
M12x1.75	12	0.5	48	24	18	24	12	0.5	20	62	30	FORM12DINI
M16x2	16	1	64	32	24	32	16	1	26	83	39	FORM16DINI

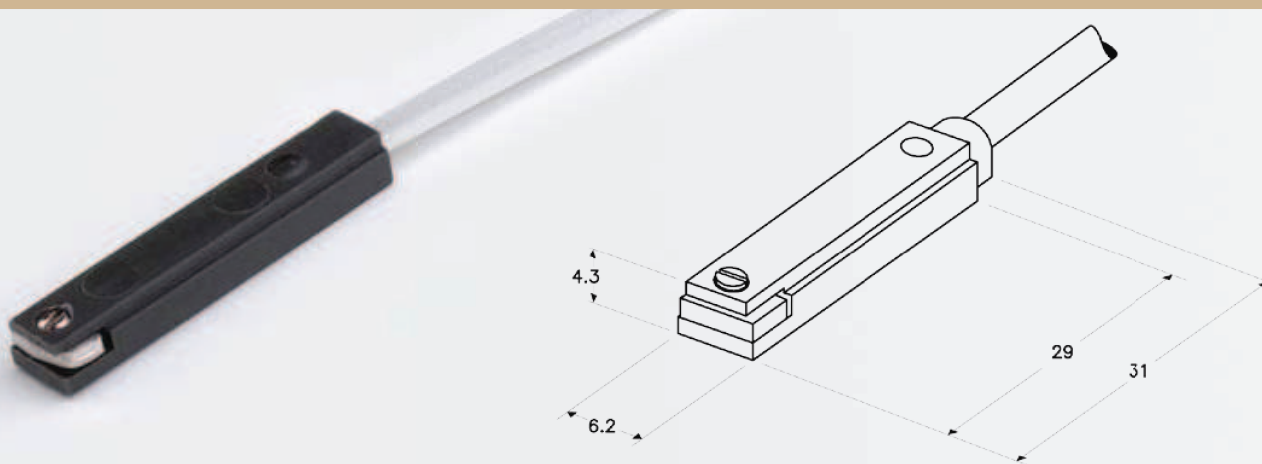

SERIE / SERIES	ZS		
Interruttore con cavo <i>Switch with cable</i>	ZS3201	ZS3300	ZS4300
Interruttore con connettore M8 <i>Switch with connector M8</i>	ZS3210	ZS3310	ZS4301
Tipo Sensore <i>Sensor Type</i>	Contatto reed N.O. <i>Reed switch N.O.</i>	Contatto reed PNP N.O. <i>Reed switch PNP N.O.</i>	Magneto-resistivo PNP N.O. <i>Magneto-resistive PNP N.O.</i>
Tensione di alimentazione <i>Power supply</i>	3÷30 V ac/dc		3÷30 V dc
Corrente di commutazione <i>Switching current</i>	0.2 A		
Potenza (carico ohmico) <i>Power (ohmic load)</i>	6 W		
Caduta di tensione <i>On voltage drop</i>	≤ 3 V	/	≤ 1 V
Tempo commutazione "ON" <i>Response time "ON"</i>	0.5 ms		0.8 μs
Tempo commutazione "OFF" <i>Response time "OFF"</i>	0.1 ms		0.3 μs
Punto di lavoro nominale <i>Nominal operate point</i>	20÷25 AT		40 Gauss (34-46) Gauss
Differenza ON-OFF <i>ON-OFF differential</i>	5÷10 AT		5÷15 Gauss
Temperatura lavoro <i>Operating temperature</i>	-10 ÷ +70 °C		
Frequenza di lavoro <i>Operating frequency</i>	max 500 Hz		max 200 KHz
Vita elettrica <i>Life time</i>	10 ⁷ imp		10 ⁹ imp
Protezione contro inversione di polarità <i>Polarity reversal protection</i>	SI / YES		
Protezione contro corto-circuito <i>Short circuit protection</i>	/		
Grado di protezione <i>Environmental protection degree</i>	IP 67		
Configurazioni circuitali <i>Wiring schematics</i>			

CAVI PER SENSORI

SENSORS CABLES

CONNETTORE M8 M8 CONNECTOR

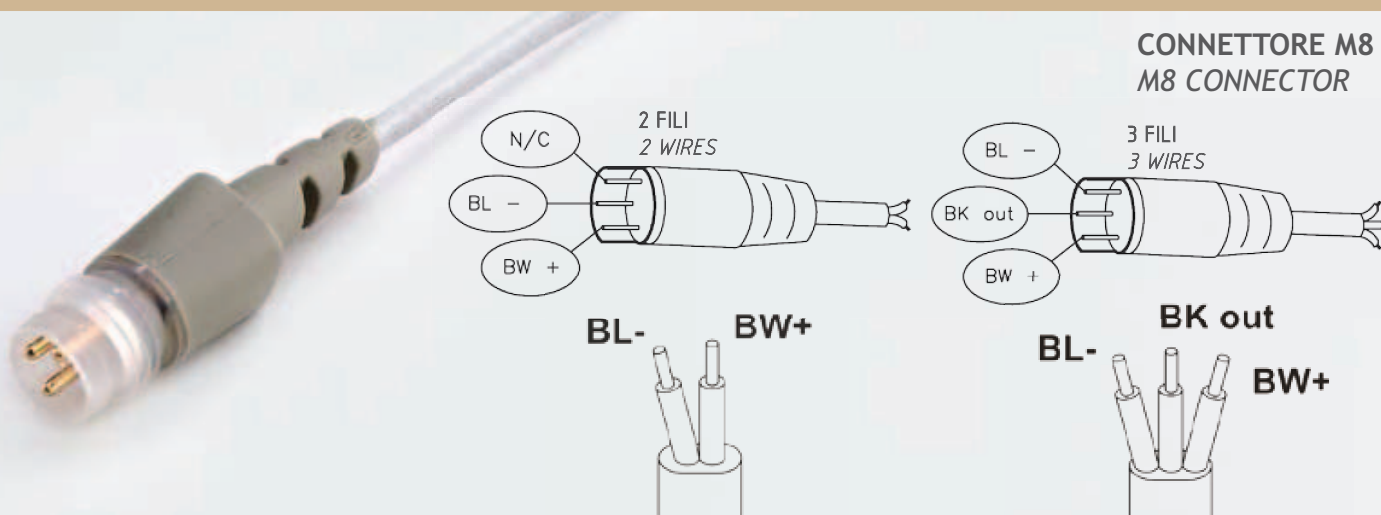

Lunghezza cavo standard Standard cable length	2.5 m (cavo diretto / flying connector with cable) 0.3 m (cavo con connettore / plug connector with cable)
Conduttori Conductors	0.14 mm ² / AWG 26 / (36x 0.07 mm ²)
Isolamento Isolation	PVC
Guaina Sheath	PVC ø 2.7 mm
Test di fiamma Flame test	V2
Certificazione Certification	CEI EN 60529; CEI EN 60947-5-2; CEI EN 61000-6-2; CEI EN 61000-6-3; CEI EN 55022; CEI EN 61000-4-2; CEI EN 61000-4-3 CEI EN 61000-4-4; CEI EN 65000-4-5; CEI EN 61000-4-8; CEI EN 61000-4-11; CEI EN 61000-4-6

CIRCUITI DI PROTEZIONE PER SENSORI	PROTECTION CIRCUIT FOR SWITCHES
<p>La commutazione di carichi induttivi da parte dei contatti REED produce un elevato picco di tensione al momento della disinserzione. Per tale motivo, al fine di prevenire eventuali scariche dielettriche oppure un arco voltaico, è necessario introdurre un circuito di protezione. Questo può essere:</p> <ul style="list-style-type: none"> -un circuito R-C in parallelo al fincorsa se alimentato in V dc -(vedi Fig.1) -un diodo in parallelo al carico se alimentato in V dc - (vedi Fig.2) -n°2 diodi Zener in parallelo al carico se alimentato in V ac/dc - (vedi Fig.3) -un varistore (VDR) in parallelo al carico se alimentato in V ac/dc - (Fig.4) <p>La commutazione di carichi capacitivi o l'impiego di cavi con lunghezza maggiore a metri 10 produce picchi di corrente al momento dell'inserzione. Perciò è necessario prestare attenzione garantendo la minima corrente necessaria per pilotare il sensore. (10=20 mA).</p>	<p>The switching of inductive loads made by REED produces an high voltage peak during the drop-out. In order to prevent dielectric discharges or voltaic arcs, you have to introduce a protection circuit. It can be:</p> <ul style="list-style-type: none"> -a R-C circuit in parallel to the switch in case of V dc supply - (Img.1) -a diode in parallel to the load in case of V dc supply - (Img.2) -n°2 Zener diodes in parallel to the load with V ac/dc supply - (Img.3) -a varistor (VDR) in parallel to the load with V ac/dc supply - (Img.4) <p>The switching of capacitive loads or the use of cables longer than 10 meters produces current peaks during the connection. For this reason you have to introduce a protection resistance near the switch on the brown wire. Please, pay attention in granting the minimum necessary current to the switch. (10=20 mA)</p>
<p>.1</p>	<p>.3</p>
<p>.2</p>	<p>.4</p>

FISSAGGI PER SENSORI - CILINDRI TONDI

MOUNTING PARTS FOR SENSORS - ROUND CYLINDERS

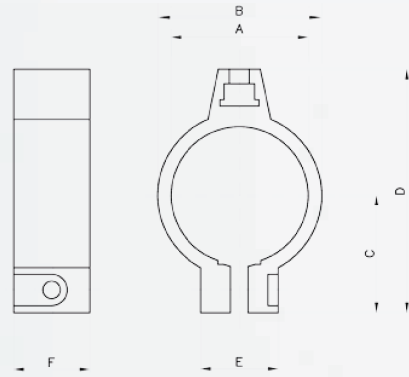

Ø mm cilindro cylinder	A	B	C	D	E	F	CODICE/CODE
8	Ø 9.3	12.3	11.1	23.9	12.3	9	NT-08
10	Ø 11.3	14.3	12.2	25.9			NT-10
12	Ø 13.3	16.3	13.2	28			NT-12
16	Ø 17.3	20.3	15.3	32.1			NT-16
20	Ø 21.3	24.3	17.4	36.2	14		NT-20
25	Ø 26.5	29.5	20	41.4			NT-25

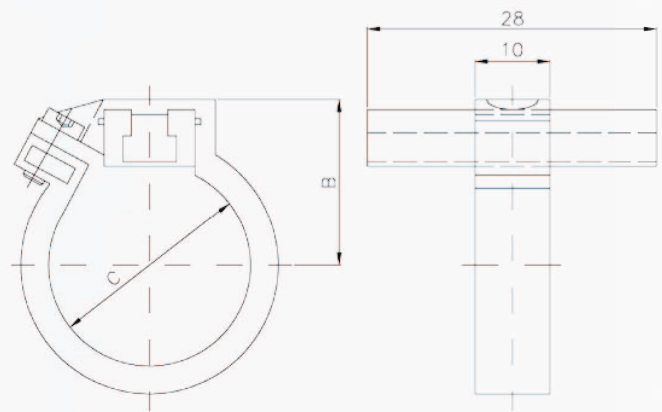

Ø mm cilindro cylinder	B	C	CODICE/CODE
32	27	33.6	NT-32
40	31	41.6	NT-40
50	37	52.4	NT-50
63	42	65.4	NT-63

FISSAGGI PER SENSORI - CILINDRI TIRANTATI

MOUNTING PARTS FOR SENSORS - TIE ROD CYLINDERS

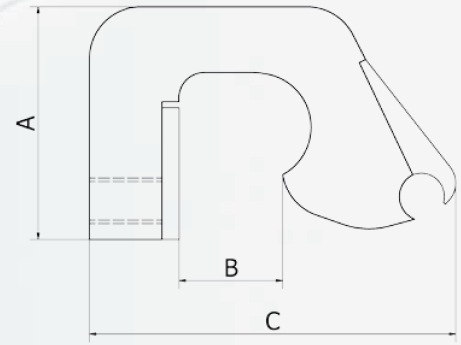

Ø mm cilindro cylinder	A	B	C	CODICE/CODE
32-63	14	9	22	NT-3263XR
80-100	19	12	34	NT-80100XR
125	21	14	33	NT-125XR
160-200	26	18	42	NT-160200XR
250	26	20.5	42	NT-250XR
320	26	25.5	42	NT-320XR

COPERTURA PER CAVA SENSORE

COVERING FOR SENSOR SLOT



MATERIALE/MATERIAL	COLORE/COLOR	LUNGHEZZA/LENGHT	CODICE/CODE
PLASTICA/PLASTIC	BLU/BLUE	0.5	XLB-11